



fill level



water level



pressure



temperature



flow



visualization



signal converter



sensoric



Sonicont *USG2*

Ultrasonic level transmitter

Non-contact measurement of filling levels in liquids, pastes and coarse bulk materials

Technical manual
06.19

Applications

Non-contact level and volume measurement or flow measurement at open channels and measuring weirs for

- Water and waste water sector
- Process industry
- Environmental technology
- Storage tanks, storage bunkers, silos

Main features

Wide range of applications

- Measuring ranges from 2m up to 25m in liquids and bulk materials
- Installation on the wall, into front panel or onto DIN-rail
- High protection class IP65 / IP68 - flood-proof
- Pluggable Version M12
- Wide environmental and process temperature range -40°C to +85°C
- Certification ATEX II 1 G Ex ia IIC T6/T5 Ga / ATEX II 1 D Ex ia IIIC T95°C Da

High chemical resistance due to enclosure material PVDF

Self-cleaning effect of the sensor surface

Integrated temperature sensor for time-of-flight correction

Level indicator can be installed up to 300m from the level transmitter



По вопросам продаж и поддержки обращайтесь:

Архангельск (8182)63-90-72
 Астана +7(7172)727-132
 Астрахань (8512)99-46-04
 Барнаул (3852)73-04-60
 Белгород (4722)40-23-64
 Брянск (4832)59-03-52
 Владивосток (423)249-28-31
 Волгоград (844)278-03-48
 Вологда (8172)26-41-59
 Воронеж (473)204-51-73
 Екатеринбург (343)384-55-89
 Иваново (4932)77-34-06
 Ижевск (3412)26-03-58
 Иркутск (395) 279-98-46

Казань (843)206-01-48
 Калининград (4012)72-03-81
 Калуга (4842)92-23-67
 Кемерово (3842)65-04-62
 Киров (8332)68-02-04
 Краснодар (861)203-40-90
 Красноярск (391)204-63-61
 Курск (4712)77-13-04
 Липецк (4742)52-20-81
 Магнитогорск (3519)55-03-13
 Москва (495)268-04-70
 Мурманск (8152)59-64-93
 Набережные Челны (8552)20-53-41
 Нижний Новгород (831)429-08-12

Новокузнецк (3843)20-46-81
 Новосибирск (383)227-86-73
 Омск (3812)21-46-40
 Орел (4862)44-53-42
 Оренбург (3532)37-68-04
 Пенза (8412)22-31-16
 Пермь (342)205-81-47
 Ростов-на-Дону (863)308-18-15
 Рязань (4912)46-61-64
 Самара (846)206-03-16
 Санкт-Петербург (812)309-46-40
 Саратов (845)249-38-78
 Севастополь (8692)22-31-93
 Симферополь (3652)67-13-56

Смоленск (4812)29-41-54
 Сочи (862)225-72-31
 Ставрополь (8652)20-65-13
 Сургут (3462)77-98-35
 Тверь (4822)63-31-35
 Томск (3822)98-41-53
 Тула (4872)74-02-29
 Тюмень (3452)66-21-18
 Ульяновск (8422)24-23-59
 Уфа (347)229-48-12
 Хабаровск (4212)92-98-04
 Челябинск (351)202-03-61
 Череповец (8202)49-02-64
 Ярославль (4852)69-52-93

Киргизия (996)312-96-26-47

Казахстан (772)734-952-31

Таджикистан (992)427-82-92-69

Эл. почта: ang@nt-rt.ru || Сайт: <http://acscontsys.nt-rt.ru/>

1 System description

1.1 Intended use

The device is a non-contact electronic ultrasonic filling level sensor for continuous measuring of filling levels in liquids, pastes and coarse bulk materials.

The operational reliability of the device is ensured only at the intended use.

1.2 Field of application

Due to the device construction with

- Measuring ranges from 2m to 25m
- Process temperatures from -40°C to +85°C
- Highly resistant materials PVDF and TPE-U
- Flood-protection due to hermetically sealed construction
- ATEX certification ATEX II 1 G resp. ATEX II 1 D

the device is especially suitable for the use for

- Level and volume measurement
- Flow measurement at open channels and measuring weirs

for

- Water and waste water sector
- Process industry
- Environmental technology
- Storage tanks, storage bunkers, silos

The level sensor is suitable for demanding measuring requirements.

The integrated temperature sensor for run-time correction allows an accurate measurement also at temperature variations.

Due to the measuring principle the sensor has a self-cleaning effect and thus reduces build-up formation.

Due to the construction type, separated from the level indicator, and cable length of up to 300m, the sensor can be installed very flexible, also in rough ambient conditions.

The robust design and the high-quality workmanship turns the device into a very high quality product, which even the most adverse environmental conditions cannot affect, whether the lowest temperatures when used outdoors, extreme shock and vibration or aggressive media.

A captive laser marking of the type label ensures the identifiability throughout the entire lifetime of the device.

Obviously is the optional marking of a measurement point designation resp. TAG, a customer label or of a neutral type label, of course also per laser marking.

A LABS-free resp. silicone-free version is optionally available.

1.3 System components

The device consists on the components:

- Sensor tip with ultrasonic sensor and temperature sensor
- Process connection, for installation into the container cover or a bracket.
- Terminal enclosure, for protection of the integrated signal processing electronic
- Connection cable for the electrical connection.

The components cannot be separated by the user.

1.4 Function

1.4.1 Measuring principle

The transducer of the ultrasonic sensor transmits ultrasonic pulses to the product surface. These pulses are reflected by product surface and received back by the transducer as echoes.

The running time of the ultrasonic pulses from emission to reception is proportional to the distance and hence the level.

The environmental temperature is measured by the integrated temperature sensor.

1.4.2 Signal processing

The received ultrasonic echo is converted by the sensor into an electrical signal and amplified by the integrated evaluation electronic.

The amplified distance signal is transmitted to the associated level indicator.

The temperature, which is measured by the temperature sensor is converted into an electrical signal and also transmitted to the associated level indicator.

The associated level indicator compensates the temperature conditioned changes in the velocity of sound by using the temperature signal and analyzes following the distance signal.

2 Safety notes

2.1 Operational safety

The device is safely built and tested according to state-of-the-art technology and has left the factory in perfect condition as regards technical safety.

The device meets the legal requirements of all relevant EU directives. This is confirmed by attaching the CE mark.

2.2 Installation, connection, commissioning, operation

Installation, electrical connection, commissioning and operation of the device must be made by a qualified and authorized expert according to the information's in this technical manual and the relevant standards and rules. This expert must have read and understood this technical manual and especially the safety notes.

The device may only be used within the permitted operation limits that are listed in this technical manual. Every use besides these limits as agreed can lead to serious dangers.

The materials of the device must be checked for compatibility with the respective application requirements (contacting materials, process temperature) before use. An unsuitable material can lead to damage, abnormal behavior or destruction of the device and to the resulting dangers.

The sensors may not be used as sole device for prevention of dangerous conditions in machines and plants.

Using the device in a manner that does not fall within the scope of its intended use, disregarding this instruction, using under-qualified personnel, or making unauthorized alterations releases the manufacturer from liability for any resulting damage. This renders the manufacturer's warranty null and void.

2.3 Operating supplies for explosive hazardous areas

If a device is installed and operated in explosive hazardous areas, the general Ex construction standards (EN/IEC 60079-14, VDE 0165), these safety notes and the enclosed EU-Type examination certificate incl. supplements must be observed.

The installation of explosive hazardous systems must be carried out principally by specialist staff.

The device meets the classification:

ATEX II 1 G Ex ia IIC T6 Ga	$T_a = -40^{\circ}\text{C} \dots +70^{\circ}\text{C}$
ATEX II 1 G Ex ia IIC T5 Ga ATEX II 1 D Ex ia IIIC T95°C Da	$T_a = -40^{\circ}\text{C} \dots +85^{\circ}\text{C}$

The devices are conceived for measurement of levels at liquids or bulk materials in explosive hazardous areas, which needs devices of category 1.

The measured medium may also be combustible liquids or vapors.

The device can be mounted in explosive hazardous areas, where devices of category 1 are required. Devices of category 1 may be operated in hazardous explosive areas that require apparatus of category 1 only if atmospheric conditions are present (pressure from 0,8 bar to 1,1 bar). Devices of category 1 must be connected to intrinsically safe circuits of protection level ia.

The intrinsically safe signal and supply circuits safe galvanically separated from parts, which can be connected with earthing potential.

At the version electrical connection type S – cable/plug connection M12 the device is earthen for safe technical function.

Provide sufficient potential compensation along the complete cable way.

The device can be loaded electrostatic by charge separation, e.g. by wiping with dry clothes or by applying of charges – electrons or ions.

Those discharging's can ignite the following flammable mixtures: gases, vapors or fogs of liquids. For ignition of dust-air-mixtures, however the possible discharges are not strong enough.

At the chargeable plastic parts of the device like enclosure or cable, there is a danger of ignition by electrostatic discharges.

The operator has to ascertain the suitability of this equipment for his use.

A warning marking points out to the safety measures, which must be applied because of the electrostatic charging in operation and especially in the case of maintenance activities:

- avoid friction
- no dry cleaning
- no assembling in pneumatic conveying stream

3 Installation

The correct function of the device within the specific technical data can only be guaranteed, if the permitted process and environmental temperatures (see chapter „Technical data“) will not be exceeded.

3.1 Installation place

3.1.1 Level measurement

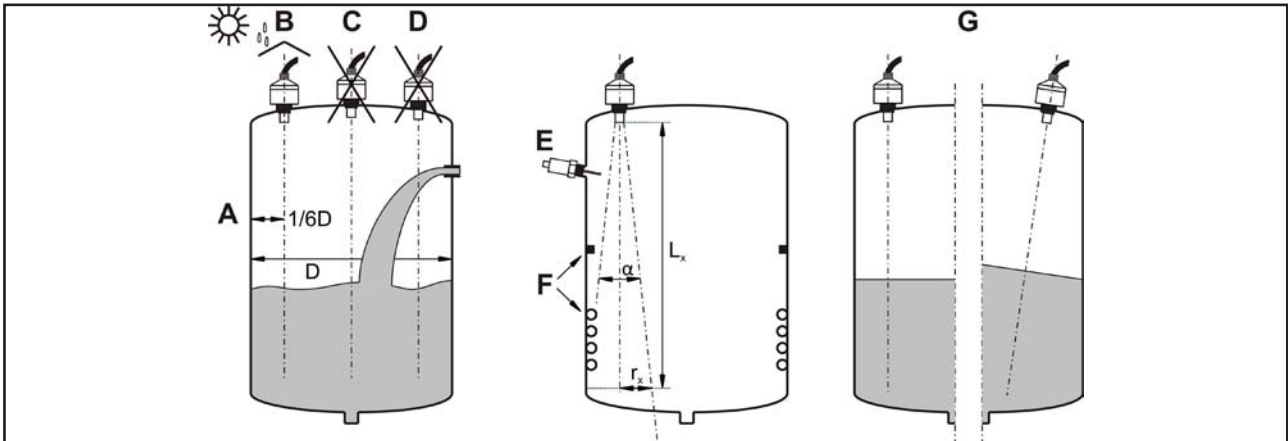

- Do not install the sensor in the middle of the tank (C). We recommend leaving a distance between the sensor and the tank wall (A) measuring $1/6D$ of the tank diameter. In vessels with conical bottom it can be advantageous to mount the sensor in the center of the vessel, as measurement is then possible down to the lowest point of the vessel bottom.
- Use a protective cover, in order to protect the device from direct sun or rain (B).
- Avoid measurements through the filling curtain (D). Through the action of filling, stirring and other processes in the vessel, dense foams which considerably damp the emitted signals may form on the product surface. If foams are causing measurement errors, the sensor should be used in a standpipe.
- If there are strong air currents in the vessel, e.g. due to strong winds in outdoor installations or air turbulence, e.g. by cyclone extraction, the device should be mount in a standpipe.
- Make sure that equipment (E) such as limit switches, temperature sensors, etc. are not located within the emitting angle α . In particular, symmetrical equipment (F) such as heating coils, baffles etc. can influence measurement. If large vessel installations such as struts or supports cause false echoes, these can be attenuated through supplementary measures. Small, inclined sheet metal or plastic baffles above the installations scatter the ultrasonic signals and avoid direct false echoes.
- Align the sensor so that it is vertical to the product surface (G).
- Never install two ultrasonic measuring devices in a tank, as the two signals may affect each other.
- To estimate the detection range, use the 3 dB emitting angle α , which can be found in the chapter "Technical Data - Input". This radius of the detection range at an arbitrary distance L_x can be calculated by the following term: $r_x = \tan(\alpha / 2) * L_x$
Example values for L_x and r_x can be found in the chapter "Technical Data - Input".

3.1.2 Installation in narrow shafts

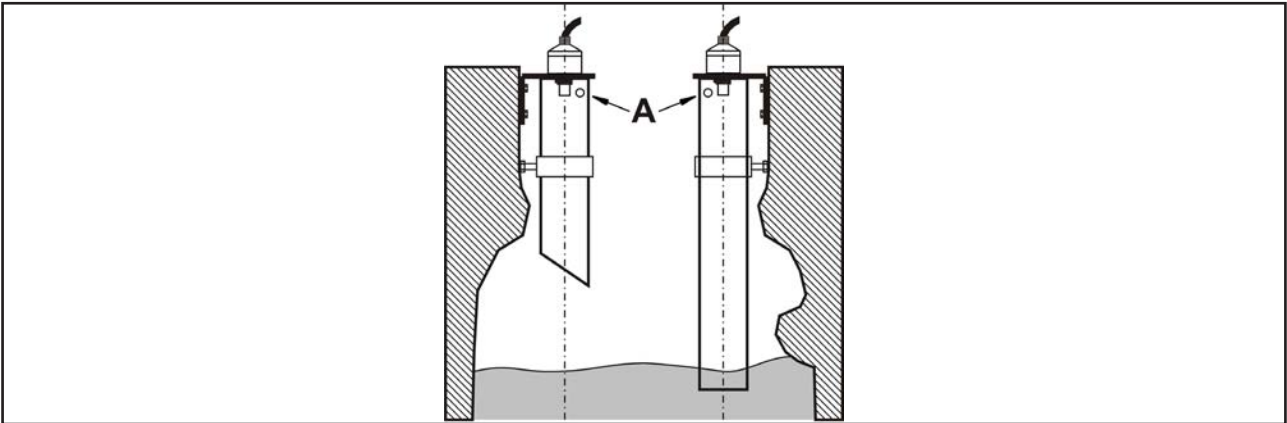

- In narrow shafts with strong interference echoes, we recommend using a stand pipe resp. an ultrasound guide pipe (e.g. PE or PVC wastewater pipe) with a minimum diameter of 100mm.
- Make sure that the pipe is not soiled by accumulated dirt. If necessary, clean the pipe at regular intervals.
- The pipe must be provided with a sufficient venting hole (A) (\varnothing 5...10mm) at the upper edge.

3.1.3 Flow measurement

Example: Triangular weir

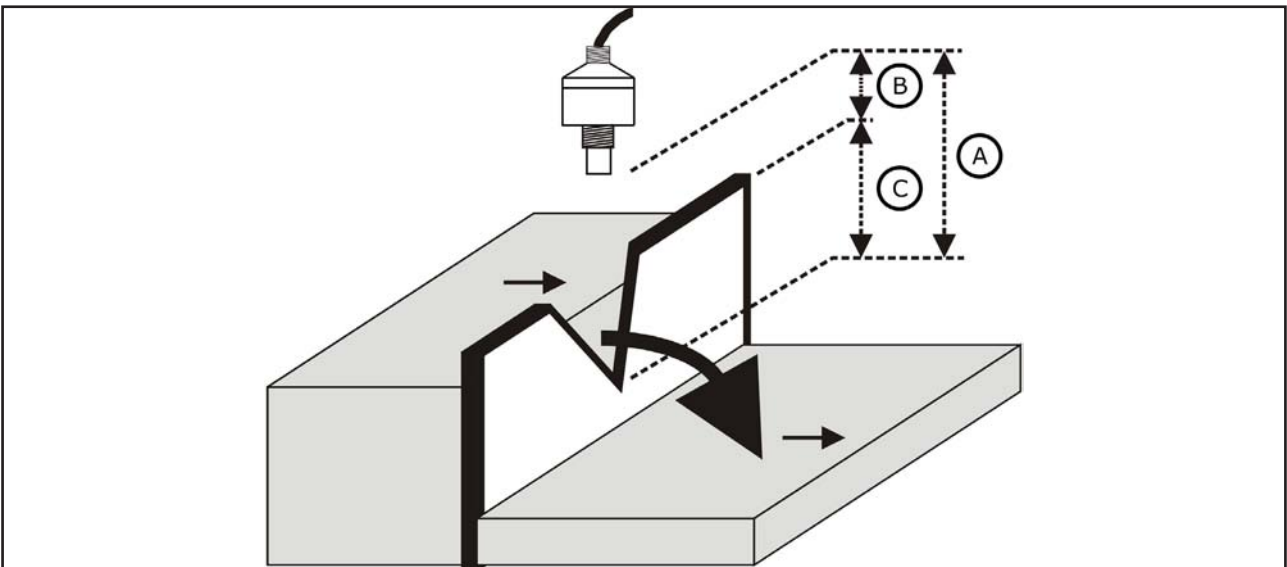

- Install the device at the inflow side, as close above the maximum water level H_{max} as possible (take into account the blocking distance BD).
- Position the device in the middle of the channel or weir.
- Align the sensor membrane parallel to the water surface.
- Keep to the installation distance of the channel or weir.

3.2 Installation notes

- Drive the system pressure free prior installation resp. deinstallation of the sensor.
- The screw-in of the thread process connection by using the connection cable is not permitted.
- The installation can be made by the front thread as well as by the rear thread.

3.2.1 Pressure / vacuum

Gauge pressure in the vessel does not influence the measuring result. Low pressure or vacuum does, however, damp the ultrasonic pulses. This influences the measuring result, particularly if the level is very low ($\leq -0,2\text{bar}$ resp. -20kPa).

3.2.2 Vapor pressure

The vapor pressure at 20°C (68°F) gives a hint on the accuracy of the ultrasonic level measurement. If the vapor pressure at 20°C (68°F) is below 50mbar , ultrasonic level measurement is possible with a very high accuracy.

This is valid for water, aqueous solutions, water-solid-solutions, dilute acids (e.g. hydrochloric acid, sulfuric acid), dilute bases (e.g. caustic soda), oils, greases, slurries, pastes, etc.

High vapor pressures or outgassing media (e.g. ethanol, acetone, ammoniac) can influence the accuracy.

3.2.3 Range

The sensor range is dependent on the measuring conditions.

The maximum range can be found in the chapter "Technical Data - Input".

3.2.4 Blocking distance

If the blocking distance is undershot, it may cause device malfunction.

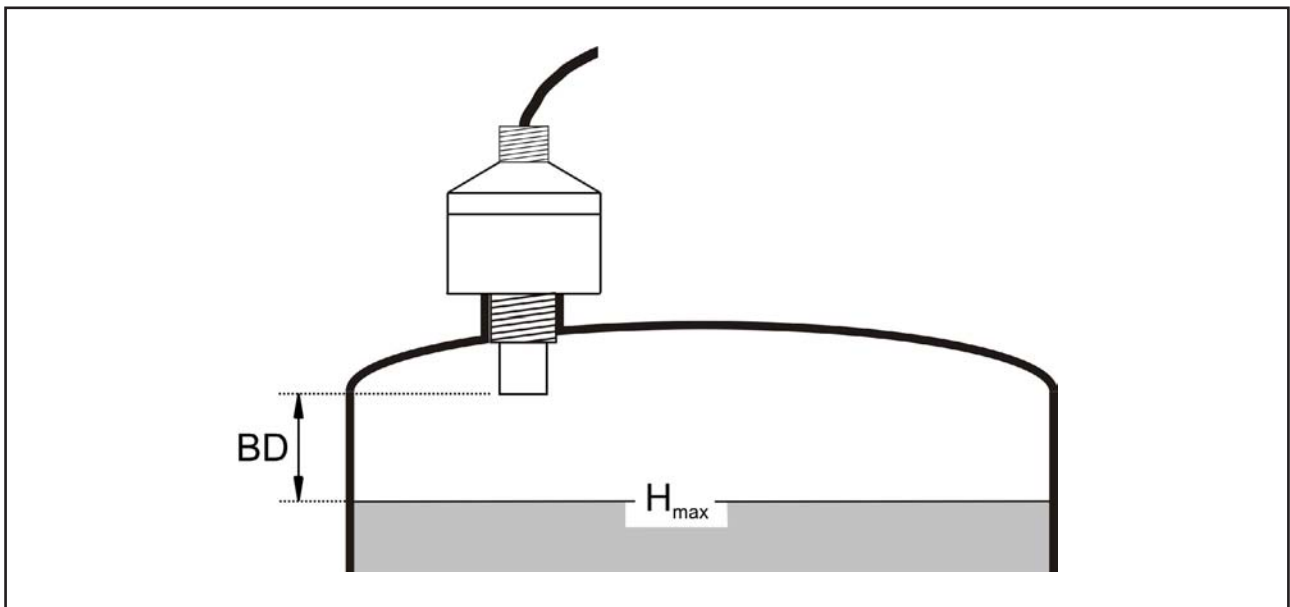

- Install the device at a height so that the blocking distance BD (see chapter "Technical Data - Input") is not undershot, even at maximum fill level H_{max} .
- If the medium reaches the transducer, buildup can form on it and cause faulty measurements later on.

3.2.5 Nozzle installation

Use a pipe nozzle if you cannot maintain the blocking distance in any other way.

- The interior of the nozzle must be smooth and may not contain any edges or welded joints. In particular, there should be no burr on the inside of the tank side nozzle end.
- To minimize disturbing factors, we recommend an angled socket edge (ideally 45°).
- Note the specified limits for nozzle diameter and length.

Nozzle diameter D	Maximum nozzle length L
DN50 / 2"	80mm
DN80 / 3"	240mm
DN100 / 4"	300mm
≥ DN150 / 6"	400mm

3.2.6 Standpipe measurement

By using a standpipe (surge or bypass tube), the influence of vessel installations, foam generation and turbulence is excluded.

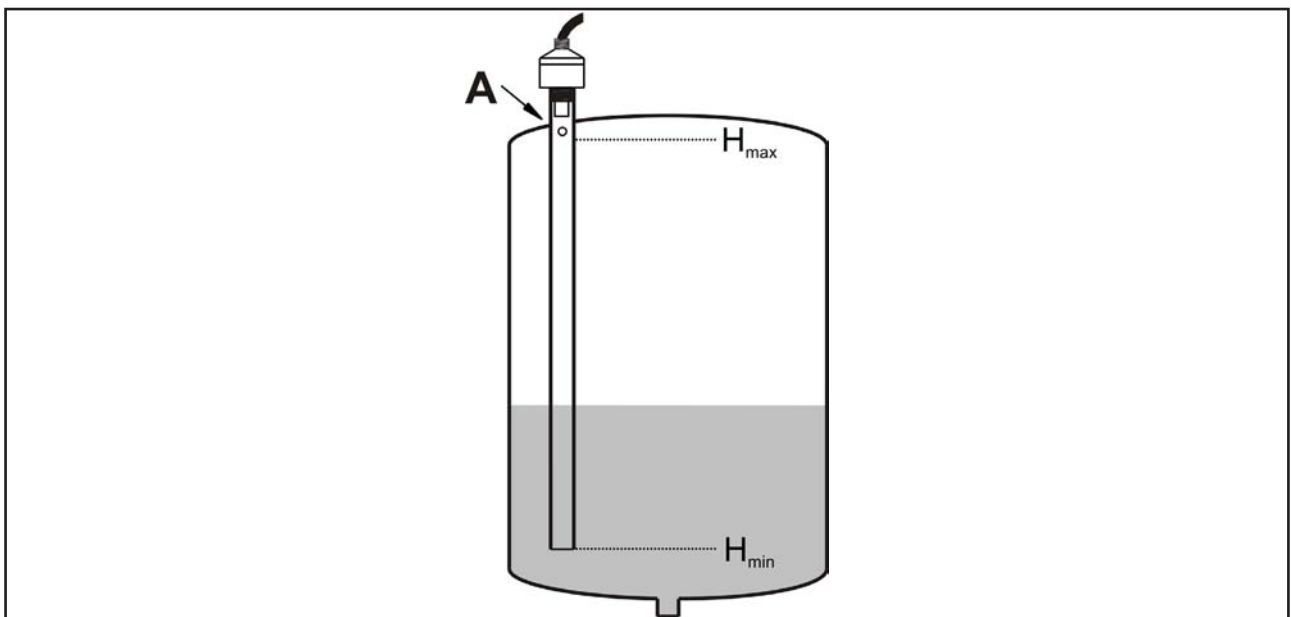

- Standpipes must extend all the way down to the requested min. level, as measurement is only possible within the tube.
- The pipe must be provided with a sufficient venting hole (A) (Ø 5...10mm) at the upper edge.
- Avoid large gaps and thick welding joints when connecting the tubes.
- Measurement in a standpipe is not recommended for very adhesive products.

4 Electrical connection

The electrical connection of the device must be carried out according to the respective country specific standards.

Incorrect installation or adjustment could cause applicationally conditioned risks.

The device is only designated for the connection to suitable level indicator.

4.1 Connection cable

In order to avoid interference signals, the connection cable should not be laid parallel to high voltage electric power lines.

The cable may not be laid in the proximity to frequency converters.

The shield of the connection cable must be connected to the terminal PE/PA of the associated level indicator.

4.1.1 Cable cut

If required, the sensor cable can be shortened.

- Do not damage the cores when removing the insulation.
- The cable is shielded by a metallic braiding. After shortening the cable, loosen the metallic braiding, twist it together securely and connect it to the terminal PE/PA of the associated level indicator.

4.1.2 Cable extension

The sensor cable can be extended to up to 300m

For extension only a suitable cable may be used:

- Construction 7x0,5mm²
- Shielding with minimum 85% coverage
- Dielectric strength wire/wire $\geq 500V$ – wire/shield $\geq 300V$
- Capacity wire/wire $\leq 55nF/km$ – wire/shield $\leq 90nF/km$
- Inductivity $\leq 0,68mH/km$
- For a sensor with ATEX certification only the original cable, available at the manufacturer, may be used.

4.2 Supply voltage

The device is supplied by the associated level indicator.

4.3 Connection scheme

The connection scheme of the associated level indicator must be observed.

4.3.1 Electrical connection type B - Cable

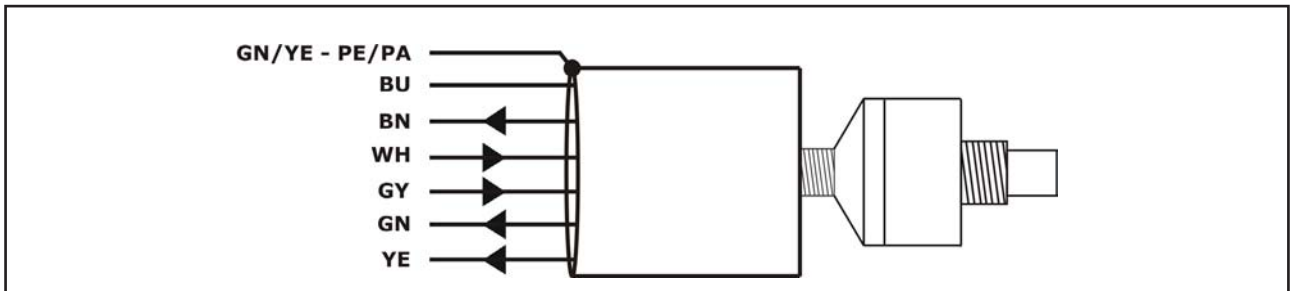

4.3.2 Electrical connection type S – Cable / plug connection M12

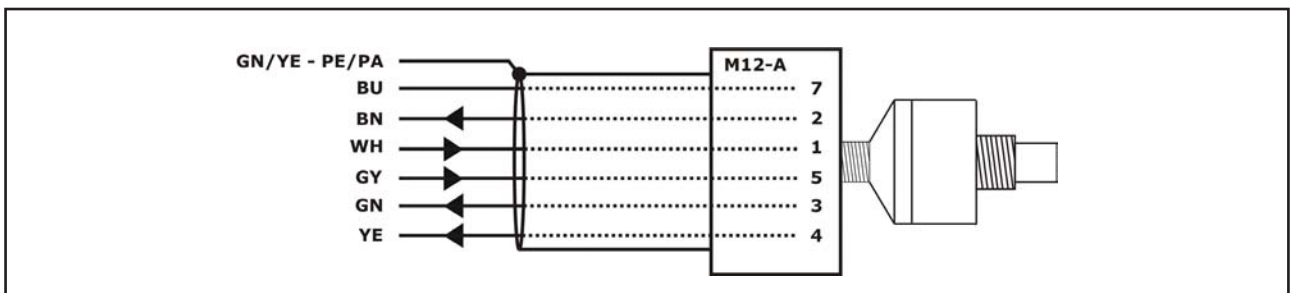

6 Service

6.1 Maintenance

The device is free of maintenance.

Special substances can lead to solid coatings on the sensor. Seized depositions can lead to faulty measurement results.

In the case of coat forming liquids the sensor must be regularly cleaned e.g. with clear water. Don't use sharp resp. hard tools or aggressive chemicals for cleaning.

6.2 Dismounting

Attention – Risk of burns!

Let the device cool down sufficiently fore dismounting it

During dismounting there is a risk of dangerously hot media escaping.

Attention – Risk of injury!

Dismount the device only when the system is pressureless.

During dismounting there is a risk of fast escaping media resp. pressure blow.

6.3 Repair

A repair may only be carried out by the manufacturer.

If the device is sent back for repair, the following information's must be enclosed:

- An exact description of the application.
- The chemical and physical characteristics of the product.
- A short description of the occurred error.

6.4 Return

Before returning the device, the following measures must be performed:

- All adhesive product residues must be removed. This is especially important, if the product is unhealthily, e.g. caustic, toxic, carcinogenic, radioactive etc.
- A returning must be refrained, if it is not possible by 100% to remove the unhealthily product completely, because e.g. it is penetrate into cracks or is diffused through plastic.

6.5 Disposal

Dispose of instrument components and packaging materials in an environmentally compatible way and in accordance with the country-specific waste disposal regulations.

7 Technical Data

Reference conditions	EN/IEC 60770-1	
	Ideal reflective surface No interference reflections within signal beam	
	Environmental temperature	25°C
	Environmental air pressure	860..1060kPa
	Air humidity	45...75% r.h.
	Warm-up time t_{on}	240s
	Installation position	Vertical Process connection bottom

7.1 Auxiliary power supply

Supply voltage U_s	Supplied by associated level indicator
----------------------	--

7.2 Input

7.2.1 Type 020

Measuring range	$\leq 2m_{\perp}$
Blocking distance BD	$\leq 0,15m$ (typ. 0,06m)
Operating frequency f_{US}	125kHz
Emitting angle α	$10^{\circ} \pm 2^{\circ}$ (-3dB)
Detection radius r_x	$r_x = 0,087m$ ($L_x = 1,0m / \alpha = 10^{\circ}$) $r_x = 0,175m$ ($L_x = 2,0m / \alpha = 10^{\circ}$)
Pulse rate t_p (measure cycle time)	5Hz (200ms) 2,5Hz (400ms) 1,25Hz (800ms)

7.2.2 Type 050

Measuring range	$\leq 5m_{\perp}$
Blocking distance BD	$\leq 0,20m$ (typ. 0,15m)
Operating frequency f_{US}	75kHz
Emitting angle α	$14^{\circ} \pm 2^{\circ}$ (-3dB)
Detection radius r_x	$r_x = 0,307m$ ($L_x = 2,5m / \alpha = 14^{\circ}$) $r_x = 0,614m$ ($L_x = 5,0m / \alpha = 14^{\circ}$)
Pulse rate t_p (measure cycle time)	2,5Hz (400ms) 1,25Hz (800ms) 0,625Hz (1600ms)

7.2.3 Type 080

Measuring range	$\leq 8m_{\perp}$
Blocking distance BD	$\leq 0,30m$ (typ. 0,19m)
Operating frequency f_{US}	50kHz
Emitting angle α	$10^{\circ} \pm 2^{\circ}$ (-3dB)
Detection radius r_x	$r_x = 0,491m$ ($L_x = 4,0m / \alpha = 10^{\circ}$) $r_x = 0,700m$ ($L_x = 8,0m / \alpha = 10^{\circ}$)
Pulse rate t_p (measure cycle time)	1,667Hz (500ms) 0,833Hz (1000ms) 0,417Hz (2000ms)

7.2.4 Type 150

Measuring range	≤ 15m _L
Blocking distance BD	≤ 0,40m (typ. 0,35m)
Operating frequency f _{US}	41kHz
Emitting angle α	14° ±2° (-3dB)
Detection radius r _x	r _x = 0,921m (L _x = 7,5m / α = 14°) r _x = 1,842m (L _x = 15,0m / α = 14°)
Pulse rate t _p (measure cycle time)	1,667Hz (500ms) 0,833Hz (1000ms) 0,417Hz (2000ms)

7.2.5 Type 250

Measuring range	≤ 25m _L
Blocking distance BD	≤ 0,60m (typ. 0,46m)
Operating frequency f _{US}	30kHz
Emitting angle α	12° ±2° (-3dB)
Detection radius r _x	r _x = 1,314m (L _x = 12,5m / α = 12°) r _x = 2,628m (L _x = 25,0m / α = 12°)
Pulse rate t _p (measure cycle time)	1,667Hz (500ms) 0,833Hz (1000ms) 0,417Hz (2000ms)

7.3 Output

1.1.1 Distance

Signal	Analogue voltage / pulse signal
--------	---------------------------------

1.1.2 Temperature

Signal	Analogue voltage signal
--------	-------------------------

7.4 Process conditions

Process temperature	-40°C...+85°C
Process pressure	-0,3...2 bar

7.5 Environmental conditions

Environmental temperature	-40°C...+85°C
Protection	<i>Electrical connection type B – cable</i> IP65 / IP68 [≤ 1 mWs-1h] (EN/IEC 60529) <i>Electrical connection type S – cable/plug connection M12</i> IP67 (EN/IEC 60529)
Climatic classification	4K4H (EN/IEC 60721-3-4)
Shock classification	15g [11ms] (EN/IEC 60068-2-27)
Vibration classification	4g [10...2000 Hz] (EN/IEC 60068-2-6)
EM compatibility	Operation device class B / Industrial range (EN/IEC 61326)
Tightening torque	≤ 20Nm

Weight	Measuring range 020: 0,5 kg + (L1 x 0,075 kg/m) Measuring range 050: 0,5 kg + (L1 x 0,075 kg/m) Measuring range 080: 0,6 kg + (L1 x 0,075 kg/m) Measuring range 150: 0,7 kg + (L1 x 0,075 kg/m) Measuring range 250: 0,9 kg + (L1 x 0,075 kg/m)
--------	---

7.6 Materials

7.6.1 Process wetted

Sensor	PVDF
Process connection	Measuring range 020/050/080/150: PVDF Measuring range 250: PVDF, PBT Valox

7.6.2 Not process wetted

Sensor rear side	PVDF
Connection cable	TPE-U <ul style="list-style-type: none"> - weather-resistant - oxygen and ozone resistant - hydrolysis resistant - microbe resistant - halogen-free - LABS-free (silicone and cadmium-free) - low-adhesion - flame-retardant
Plug M12	CrNi steel
Cable socket M12	Zinc die-cast, nickel-plated

8 Dimension drawings

8.1 Process connection

Measuring range 020 - ≤ 2m / Process connection G15 - Thread ISO 228-1 - G1½"

Measuring range 050 - ≤ 5m / Process connection G15 - Thread ISO 228-1 - G1½"

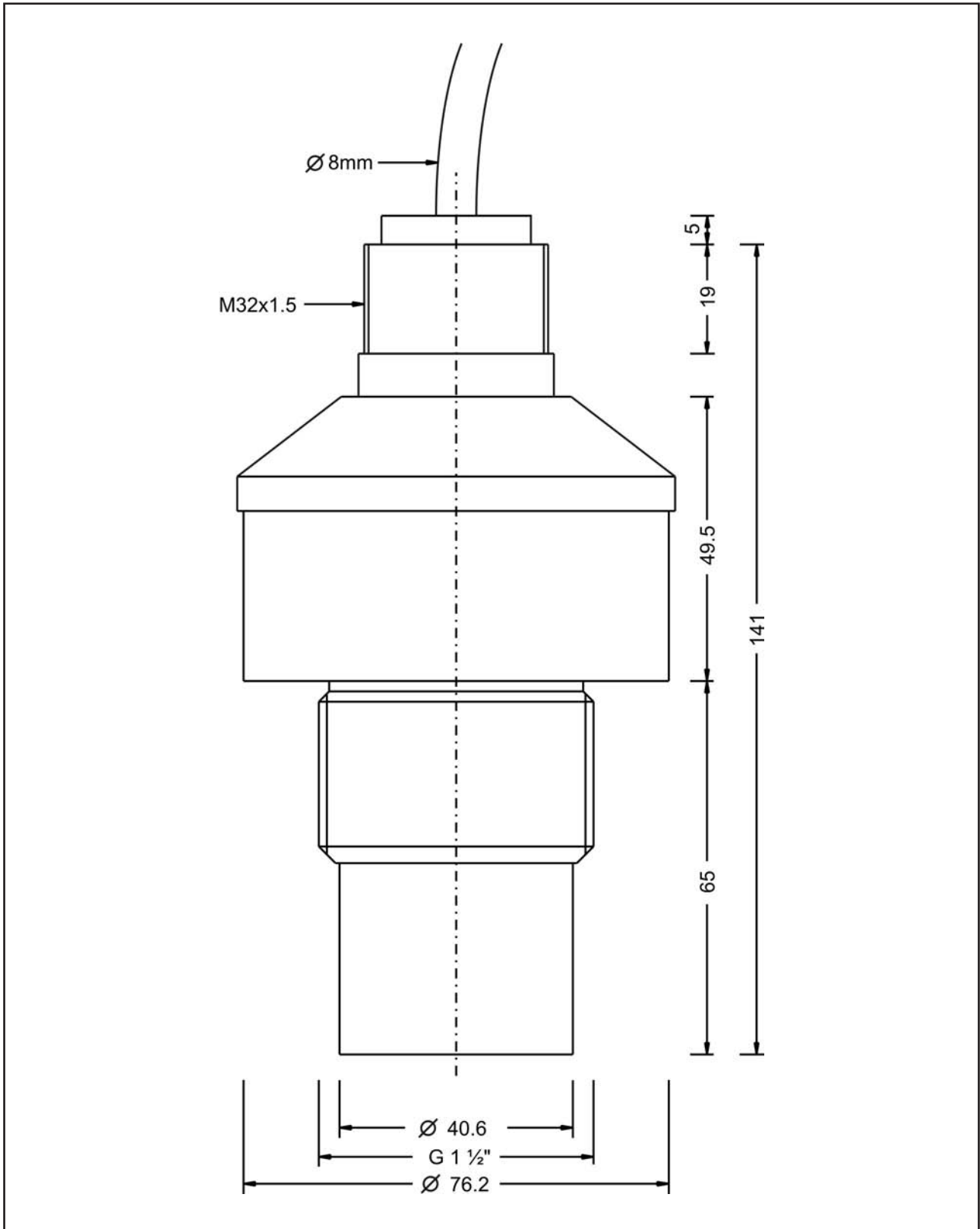

Delivery incl. 1x nut thread ISO 228-1 - G1½" / 1x nut thread DIN 13 - M32x1,5

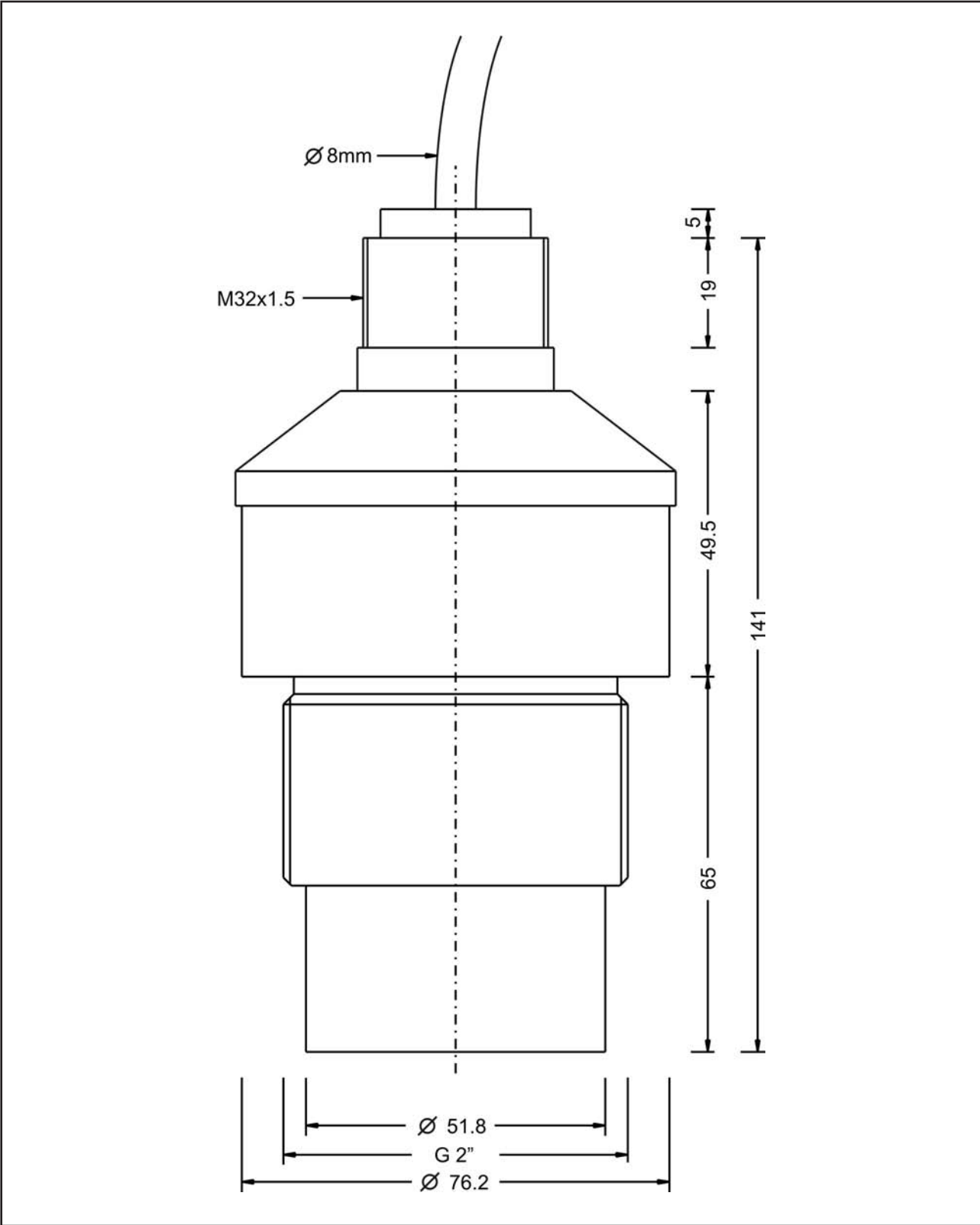

Delivery incl. 1x nut thread ISO 228-1 – G2" / 1x nut thread DIN 13 – M32x1,5

Measuring range 150 - ≤ 15m / Process connection M32 - Thread DIN 13 - M32x1,5

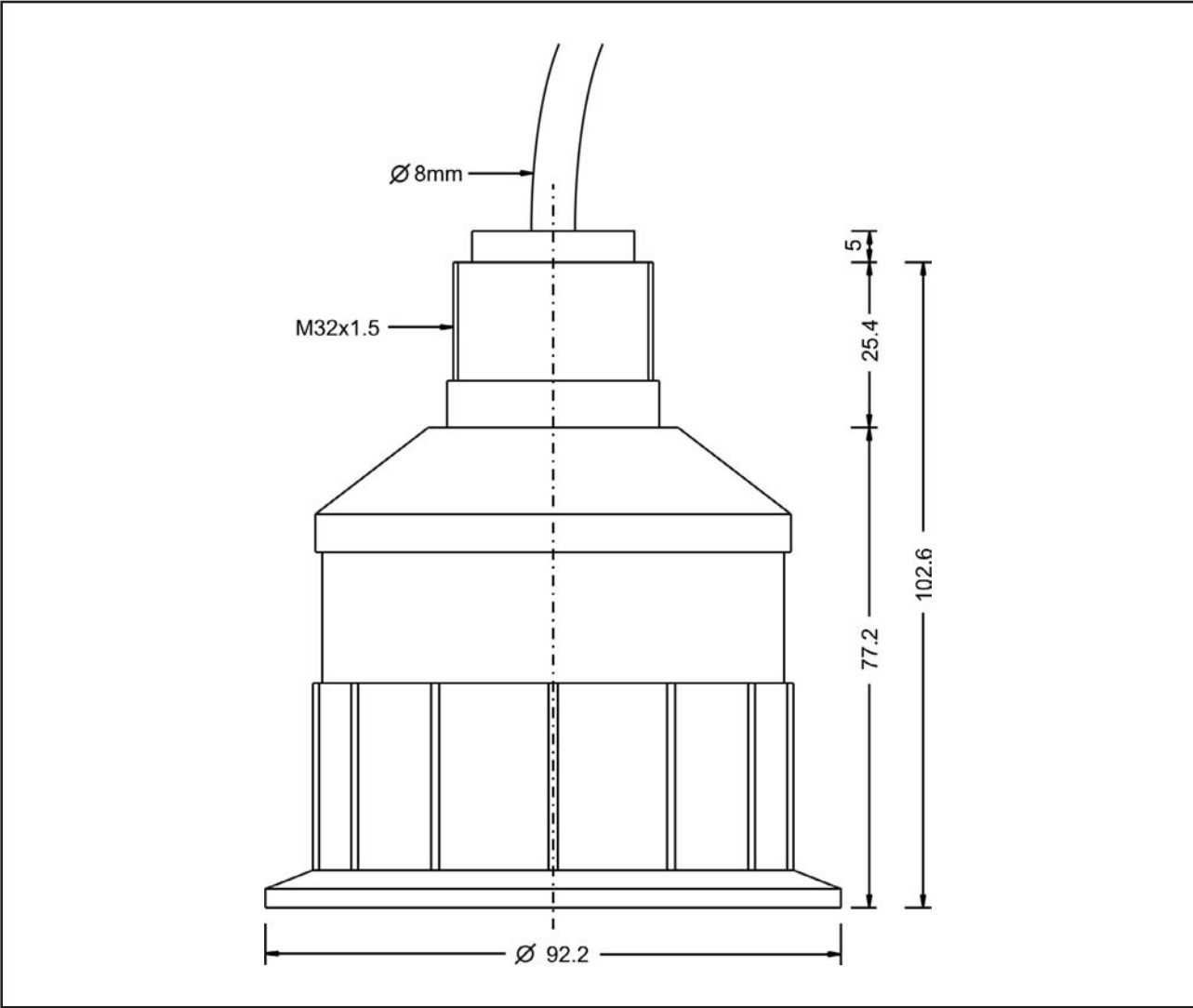

Delivery incl. 1x nut thread DIN 13 - M32x1,5

Measuring range 250 – ≤ 25m / Process connection M32 – Thread DIN 13 – M32x1,5

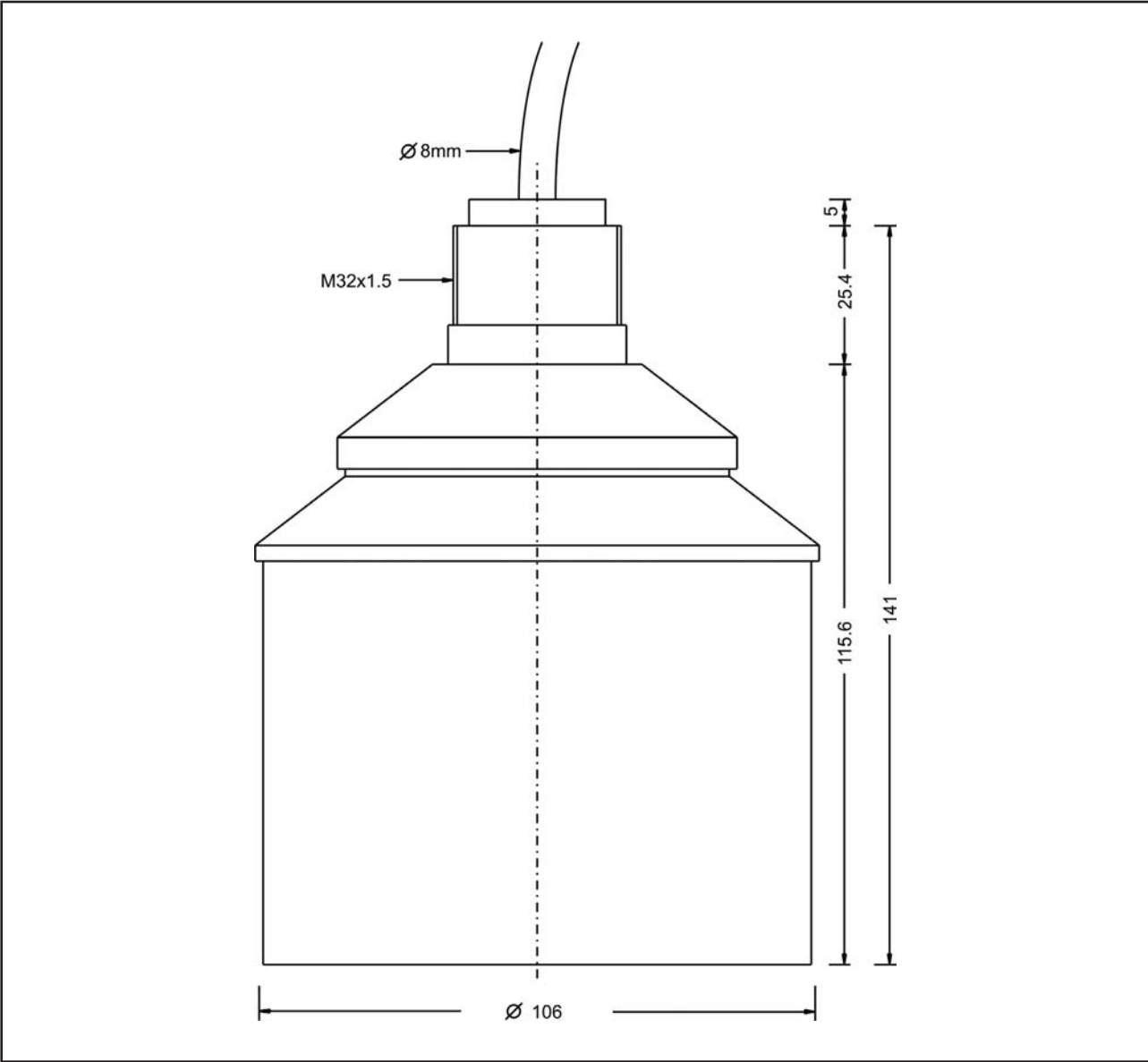

Delivery incl. 1x nut thread DIN 13 – M32x1,5

9 Ordering information

9.1 Order code

Type
USG2 Standard

Measuring range
020 2m
050 5m
080 8m
150 15m
250 25m

Approval
0 Standard
X ATEX II 1 G Ex ia IIC T6/T5 Ga / ATEX II 1 D Ex ia IIIC T95°C Da

Process connection
G15 Thread ISO 228-1 – G1½", Thread DIN 13 – M32x1,5
G20 Thread ISO 228-1 – G2", Thread DIN 13 – M32x1,5
M32 Thread DIN 13 – M32x1,5

Material process connection (process wetted)
P PVDF (Measuring range 020 / 050 / 080 / 150) resp. PVDF/PBT (Measuring range 250)

Electrical connection
B Cable TPE-U
S Cable TPE-U, plug connection M12

Length L1 – connection cable
1 5m
2 10m
3 15m
4 20m
5 25m
6 30m

Order code: USG2 00P000

Sonicont

USG2

0

0

P

0

0

0

0

Installation material and connection cable are not enclosed in contents of delivery.

9.2 Additional options

For the device additional options are available.

The respective abbreviation subsequently follows the order code.

- SF LABS-free, silicone-free / paint compatible version
- ML Measurement point designation / TAG – Laser marking
- KL Customer label on device – Laser marking
- TN Type label neutral

9.3 Accessories

Accessories are not content of delivery of the device and must be ordered separately.

9.3.1 Installation material

A wide range of accessories for device installation is constantly available, e.g.

- Welding sockets
- Welding flanges
- Blind flanges
- Flanges with thread
- Reductions
- Tube nuts
- Mounting bracket
- Weather protection cover
- Marking plate measuring point, laser marked
- etc.

9.3.2 Connection cable

- Connection cable 7x0,5mm², material TPE-U, shielded

По вопросам продаж и поддержки обращайтесь:

Архангельск (8182)63-90-72
Астана +7(7172)727-132
Астрахань (8512)99-46-04
Барнаул (3852)73-04-60
Белгород (4722)40-23-64
Брянск (4832)59-03-52
Владивосток (423)249-28-31
Волгоград (844)278-03-48
Вологда (8172)26-41-59
Воронеж (473)204-51-73
Екатеринбург (343)384-55-89
Иваново (4932)77-34-06
Ижевск (3412)26-03-58
Иркутск (395) 279-98-46

Казань (843)206-01-48
Калининград (4012)72-03-81
Калуга (4842)92-23-67
Кемерово (3842)65-04-62
Киров (8332)68-02-04
Краснодар (861)203-40-90
Красноярск (391)204-63-61
Курск (4712)77-13-04
Липецк (4742)52-20-81
Магнитогорск (3519)55-03-13
Москва (495)268-04-70
Мурманск (8152)59-64-93
Набережные Челны (8552)20-53-41
Нижний Новгород (831)429-08-12

Новокузнецк (3843)20-46-81
Новосибирск (383)227-86-73
Омск (3812)21-46-40
Орел (4862)44-53-42
Оренбург (3532)37-68-04
Пенза (8412)22-31-16
Пермь (342)205-81-47
Ростов-на-Дону (863)308-18-15
Рязань (4912)46-61-64
Самара (846)206-03-16
Санкт-Петербург (812)309-46-40
Саратов (845)249-38-78
Севастополь (8692)22-31-93
Симферополь (3652)67-13-56

Смоленск (4812)29-41-54
Сочи (862)225-72-31
Ставрополь (8652)20-65-13
Сургут (3462)77-98-35
Тверь (4822)63-31-35
Томск (3822)98-41-53
Тула (4872)74-02-29
Тюмень (3452)66-21-18
Ульяновск (8422)24-23-59
Уфа (347)229-48-12
Хабаровск (4212)92-98-04
Челябинск (351)202-03-61
Череповец (8202)49-02-64
Ярославль (4852)69-52-93

Киргизия (996)312-96-26-47

Казахстан (772)734-952-31

Таджикистан (992)427-82-92-69

Эл. почта: ang@nt-rt.ru || Сайт: <http://acscontsys.nt-rt.ru/>